

MR-16

User Manual



CONTENTS

PART 1 : MR-16

1. Introduction
2. Features

PART 2 : CPU Board

1. Placement Diagram (Silkscreen)
2. [Circuit Diagram](#)
3. Parts List

PART 3 : Software Tools

1. AVR Development Program Installation
2. How to use WinAVR GCC
3. How to use PonyProg2000

PART 4 : Compile and Download

PART 1: MR-16

1. Introduction

MR-16 is a small pre-assembled CPU board, which has an ISP(In-System Programming) port, reset button, 8MHz X-tal, and 32 I/O port pins. The MR-16 uses an Atmega16L(Atmel AVR series) CPU chip as a controller. The Atmega16 has 16K bytes In-System Programmable Flash memory, 1K bytes SRAM, 512 bytes EEPROM and many other peripherals. The user can download a program to the board without a ROM Writer using the ISP function. A free C-compiler (WinAVR) is available.

2. Features

- Atmega16L (Atmel AVR series, 8MHz(8 MIPS))
- 16K bytes ISP flash, 1K bytes SRAM, 512 bytes EEPROM, three Timers, ADC 8ch, UART
- ISP port
- Internal Calibrated RC Oscillator
- ISP download indicating LED
- 32 I/O port pins
- Reset button
- Free Windows C compiler (Win AVR GCC)
- ISP downloader (Optional)

PART 2: BOARD

1. Placement Diagram(Silkscreen)

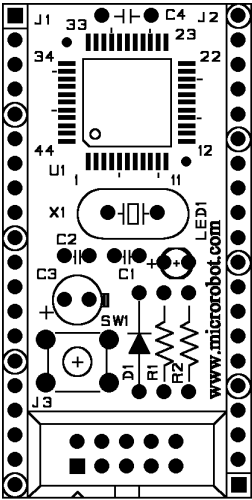
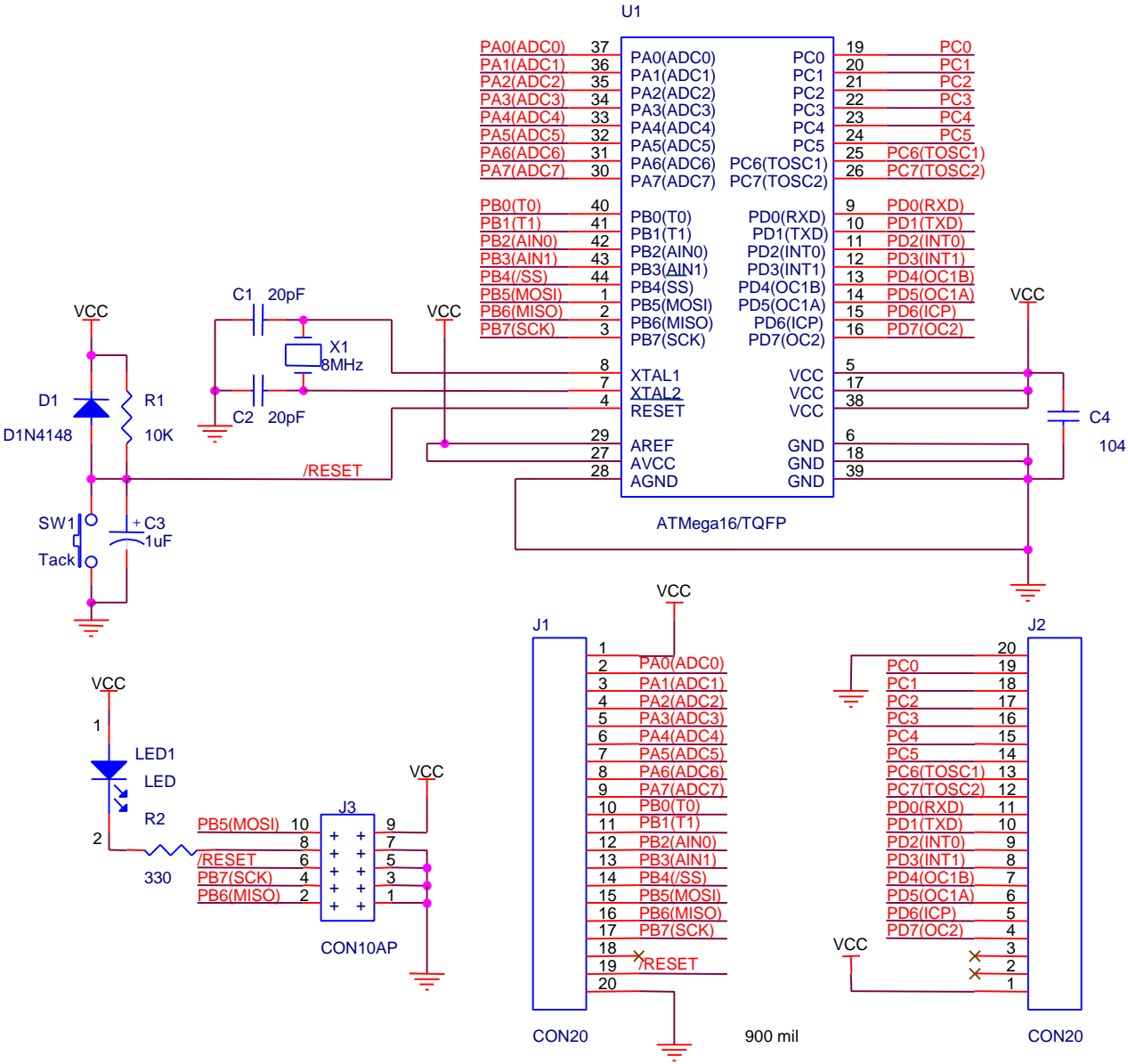

Fig 1.1 MR-16 CPU board silkscreen.

2. Circuit Diagram



3. Parts List

NO	Reference	Parts name	Value	Qty.	Remark
1	C1, C2	Capacitor	20pF	2	Ceramic Condenser
2	C3	"	1uF/16V	1	Electrolytic Condenser
3	C4	"	104	1	Monolithic Condenser
4	D1	Diode	D1N4148	1	DIP type
5	LED1	LED	RED 3ø	1	
6	J1, J2	Connector	CON20	1	1Line Header(male)
7	J3	"	CON10AP	1	HIF3F/10PIN
8	R1	Resistor	10KΩ	1	1/4W DIP type
9	R2	"	330Ω	1	1/4W DIP type
10	SW1	S/W	Tack S/W(Small)	1	
11	U1	MCU	ATmega16L/TQFP	1	AVR Microcontroller
12	X1	X-TAL	8MHz	1	ATS type
13		PCB		1	Main PCB
14		Downloading Adapter		1	Option
15		Ribbon Cable		1	Option (1 m)



Fig 2.1 Downloading Adapter



Fig 2.2 Ribbon cable

PART 3 : Software Tools

1. AVR Development Program Installation

AVR Development Tools

There are many different kinds of development tools for AVR microcontrollers. Atmel, the AVR CPU manufacturer, provides some AVR development tools free. WinAVR GCC is a free Windows C-compiler.

Wavrasn : AVR assembler, Atmel.

AVR Studio : AVR Emulator/Simulator, Atmel.

AVR ISP : ISP downloading program, Atmel.

PonyProg2000 : ISP downloading program, Lancos. **(Recommended)**

WinAVR GCC : C-compiler, GNU. **(Recommended)**

The AVR ISP downloading program does not support ATmega16 but the PonyProg2000 program does.

System requirements for AVR development tools

- Windows 9X/ME or NT/2000/XP
- Pentium-133 or higher
- At least 4 Mbytes of RAM
- CD-ROM Drive

PonyProg2000 installation:

Go to <http://www.lancos.com/> and download the latest version of PonyProg. Refer to “How to use PonyProg for Microrobot AVR Products(Eng).pdf” for details.

WinAVR GCC installation

Refer to “How to use WinAVR for Microrobot AVR Products(Eng).pdf”.

2. How to use WinAVR Gcc

Refer to “How to use WinAVR for Microrobot AVR Products(Eng).pdf”.

3. How to use PongProg2000

Refer to the ‘PonyProg Manual for Microrobot AVR Products.pdf’ and the ‘Security Bit Setting for ATMega Family.pdf’ files.

PART 4 : Compile and Download

Compile the source file and download the executable file in the following order:

- Supply DC 5V to the J1's (or J2's) #1 pin and GND to the #20 pin.
- Connect the downloading adapter to the PC printer port. Then connect the downloading adapter to the CPU board by using the ribbon cable.
- Download sample code from our website ("How to use WinAVR for Microrobot AVR Products(Eng).pdf").
- Create a source folder and copy the prototype sample code, including the makefile, from the file you've downloaded.
- Make your own source file by changing the sample source file. If you change the source file name, don't forget to change the makefile too.
- Type "make all" to compile it.
- Debug and recompile if there are any errors or warnings.
- If there are no errors, the 'Errors: none' message appears.
- Run PonyProg2000.
- Do "I/O port setup" properly. Refer to 'PonyProg Manual for Microrobot AVR Products.pdf'.
- Select 'Device → AVR micro → ATmega16'.
- Select 'File → Open Program File' and load the hex file.
- Select 'Command → Program' or press Ctrl + P to start downloading. If a 'Program Failed' message appears, select 'Command → Erase' or press Ctrl + E to erase the flash memory, and then try to program it again.
- Remove the ribbon cable from the CPU board and restart the board.

www.microrobot.com