

GENERAL SPECIFICATION OF HSR-8498HB DIGITAL ROBOT SERVO

1. TECHNICAL VALUE

CONTROL SYSTEM	: +PULSE WIDTH CONTROL 1500usec NEUTRAL	
OPERATING VOLTAGE RANGE	: 6.0V TO 7.4V	
OPERATING TEMPERATURE RANGE	: -20°C TO +60°C(-4°F TO +140°F)	
TEST VOLTAGE	: AT 6.0V	AT 7.4V
OPERATING SPEED	: 0.20sec/60° AT NO LOAD	0.18sec/60° AT NO LOAD
STALL TORQUE	: 7.4kg.cm(102.76oz.in)	9.0kg.cm(124.98oz.in)
STANDING TORQUE	: 6.7kg.cm(93.04oz.in)/5° HOLDOUT	8.1kg.cm(112.48oz.in)/5° HOLDOUT
IDLE CURRENT	: 8mA AT STOPPED	
RUNNING CURRENT	: 200mA/NO LOAD RUNNING	240mA/NO LOAD RUNNING
STALL CURRENT	: 1200mA	1480mA
DEAD BAND WIDTH	: 5usec	5usec
OPERATING TRAVEL	: 45±5°/ONE SIDE PULSE TRAVELING 900usec	
DIRECTION	: CLOCK WISE/PULSE TRAVELING 1500 TO 1900usec	
MOTOR TYPE	: CORED METAL BRUSH	
POTENTIOMETER TYPE	: 4 SLIDER/INDIRECT DRIVE	
AMPLIFIER TYPE	: DIGITAL AMPLIFIER WITH MOSFET DRIVE	
DIMENSIONS	: 40x20x37mm(1.57x0.78x1.45in)	
WEIGHT	: 54.7g(1.92oz)	
BALL BEARING	: DUAL/MR106	
GEAR MATERIAL	: HEAVY DUTY RESIN GEARS	
HORN GEAR SPLINE	: 24 SEGMENTS/φ5.76	
SPLINED HORNS	: HSR-8498HB USE ONLY/HSR8498TSH, HSR8498BSH	
CONNECTOR WIRE LENGTH	: 400mm(15.74inch)	
CONNECTOR WIRE STRAND COUNTER	: 60EA	
CONNECTOR WIRE GAUGE	: 22AWG	

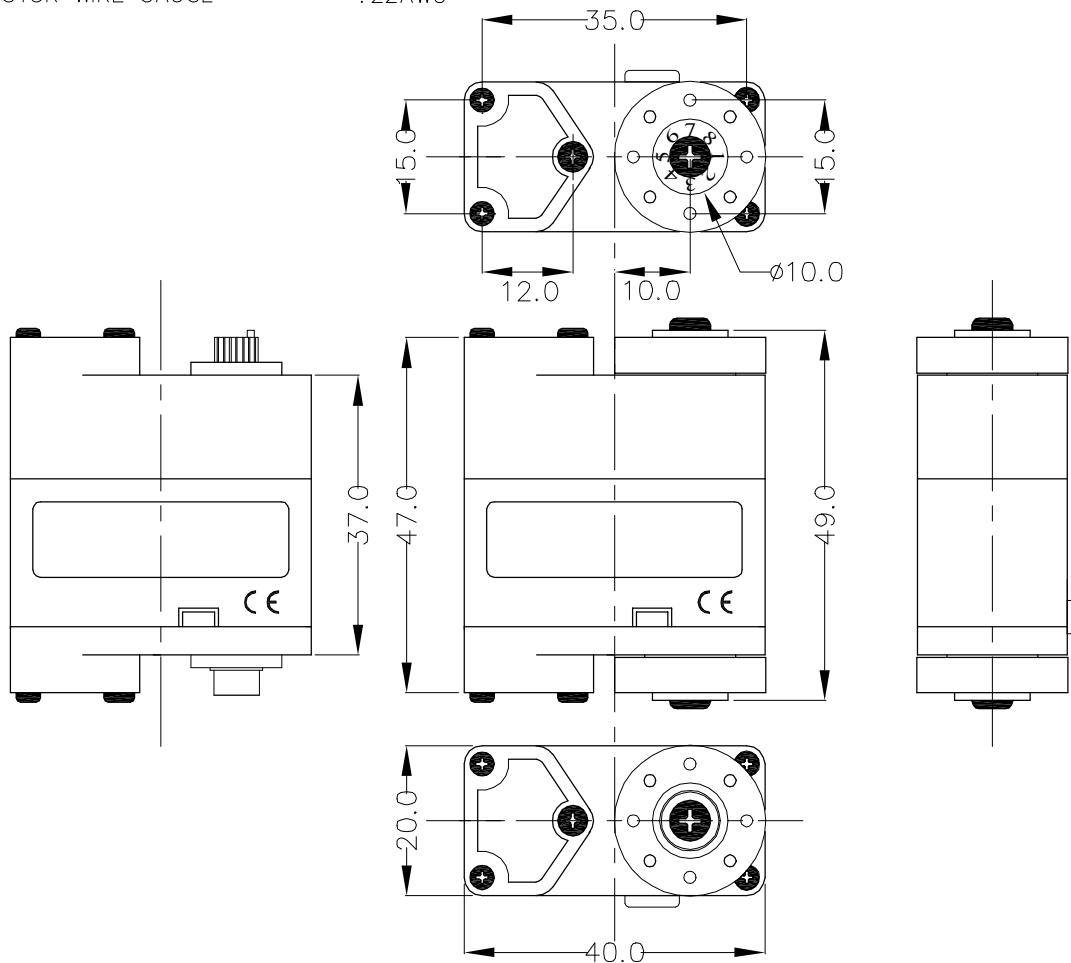

2. FEATURES

- PROGRAMMABLE DIGITAL AMPLIFIER WITH MOSFET DRIVE
- DURABLE HEAVY DUTY RESIN GEARS WITH DUAL BALL BEARING
- BOTTOM SIDE AXIAL MOUNT HOLE

3. APPLICATIONS

- ROBOTS